

SE 2550

MARINE VHF RADIO

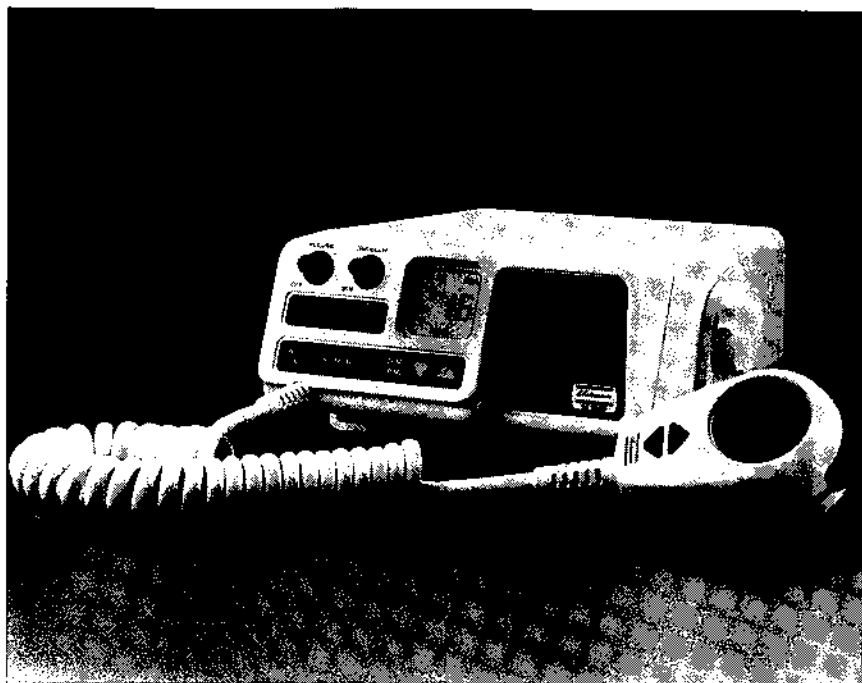

OWNER'S HANDBOOK

Shakespeare[®]

TABLE OF CONTENTS

| | | | | | |
|------------|--|-----------|------------------------|---|-----------|
| 1.0 | Introduction..... | 1 | 3.2.6 | Voice Transmitting..... | 15 |
| 1.1 | Purpose..... | 1 | 3.2.7 | High/Low Transmit Power.... | 16 |
| 1.2 | Equipment Description..... | 2 | 3.2.8 | Transmitter 3 Minute Time Out..... | 16 |
| 1.3 | Supplied Parts..... | 2 | 3.2.9 | Weather Channels Access.... | 16 |
| 1.4 | Optional Accessories..... | 2 | 3.2.10 | Channel 16 Priority..... | 17 |
| 1.5 | License Requirements..... | 3 | 3.2.11 | Channel 13/67 High Power Override..... | 17 |
| 1.5.1 | License Application..... | 3 | 3.2.12 | All Channel Scan..... | 17 |
| 1.5.2 | Operator's License..... | 3 | 3.2.13 | Memory Scan..... | 17 |
| 1.6 | Brief Operating Instructions... | 4 | 3.2.14 | Dual Watch..... | 18 |
| 1.7 | Technical Specifications..... | 6 | 3.2.15 | Hailer Operation..... | 19 |
| 2.0 | Installation..... | 7 | 3.2.16 | External Speaker Operation.. | 19 |
| 2.1 | Unpacking And Inspection... | 7 | 3.2.17 | Tone Control..... | 19 |
| 2.2 | Mounting Preparation..... | 7 | 3.2.18 | Speaker Mike..... | 19 |
| 2.3 | Mounting Location Selection..... | 7 | 3.3 | Methods Of Operation..... | 19 |
| 2.4 | Front Panel Reversal..... | 8 | 4.0 | Appendix..... | 20 |
| 2.5 | Unit Mechanical Installation..... | 9 | Appendix A..... | 20 | |
| 2.6 | Electrical Connections..... | 9 | | USA VHF Marine Channel Assignments | |
| 2.6.1 | Power Hookup..... | 9 | Appendix B..... | 21 | |
| 2.6.2 | Antenna Connection..... | 10 | | VHF Marine Weather Channel Assignments | |
| 2.6.3 | Coax Connector Assembly.... | 10 | Appendix C..... | 21 | |
| 2.6.4 | External Speaker Connection..... | 12 | | International VHF Marine Channel Assignments | |
| 2.6.5 | Hailer Connection..... | 12 | Appendix D..... | 22 | |
| 3.0 | Operation..... | 13 | | Canadian VHF Marine Channel Assignments | |
| 3.1 | Controls And Display..... | 13 | Appendix E..... | 24 | |
| 3.2 | Operating Procedures..... | 14 | | Phonetic Alphabet And Glossary | |
| 3.2.1 | Power and Volume Control.. | 14 | Appendix F..... | 25 | |
| 3.2.2 | Display Backlighting..... | 14 | | Schematics | |
| 3.2.3 | Setting Squelch..... | 14 | | | |
| 3.2.4 | Channel Selection..... | 15 | | | |
| 3.2.5 | USA/International Channel Select..... | 15 | | | |

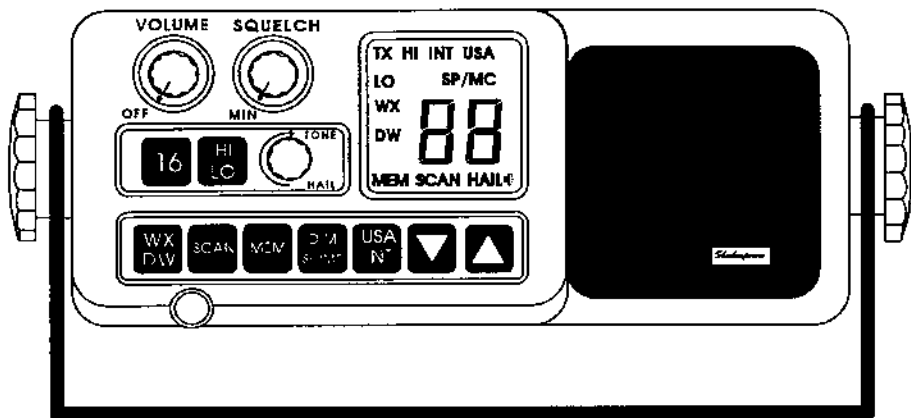

Figure 1-1 Shakespeare SE 2550 Marine VHF Radio.

1.0 INTRODUCTION

Welcome and congratulations on your purchase of the Shakespeare SE 2550 Marine VHF transceiver. You have purchased a high technology piece of marine electronics, fully backed by the Shakespeare name. The Shakespeare SE 2550 Marine VHF radio incorporates modern styling and functionality, making the radio not only easy, but pleasing to operate.

The frequency synthesized transceiver provides access to ALL usable U.S. and International Channels. Ten weather channels are also available through easy front panel key presses, making the SE 2550 a world class value in marine VHF radios.

The key to obtaining the most use and pleasure from your new VHF radio, is reading the owner's manual. This manual teaches you proper transceiver procedures and care to ensure many years of satisfying use. It is especially important to cover the areas of this manual pertaining to "License Requirements" established by the Federal Communications Commission.

1.1 Purpose

The Shakespeare SE 2550 Owner's Manual is designed to answer your questions about the installation and operation of your radio. It is important to read through the installation section before attempting to install your radio. A "Brief Operating" section assures you are on the air quickly and properly. Many new user pitfalls will be avoided by reading this manual.

1.2 Equipment Description

Your Shakespeare SE 2550 Marine VHF radio is a digitally synthesized transceiver operating in the frequency range 156-163 MHZ and constructed of the highest grade materials. All electronic components are solid state. The Shakespeare SE 2550 VHF radio offers two transmitter power settings, 1 watt and 25 watts.

The front panel is completely reversible to provide excellent overhead mounting. The large liquid crystal display shows channel numbers and mode annunciators. Red nightlighting is controllable for your comfort. A special speaker mike is provided for improved communication in a high noise environment.

Connectors are provided on the back panel of the radio for the antenna, 12 volt DC power, external speaker, and hailer.

The microprocessor control used in this radio offers features found only in far more expensive units. Features such as Dual Channel Watch, Memory Scan, Priority Channel 16, 10 Weather Channels and Hailer are only some of your Shakespeare SE 2550's many extras.

1.3 Supplied Parts

| | |
|---------------------------------|---------------------------------------|
| SE 2550 Radio Transceiver | Power Cable Assembly with fuse holder |
| Plastic Mike Clip with screws | Owner's Manual |
| Special Waterproof Speaker Mike | Waterproof Brief Instruction Card |
| Spare 7 Amp fuse | FCC Application-506 |
| Mounting Knobs (2) | FCC Restricted Operator's Permit-753 |
| Mounting Bracket | Warranty Card |

1.4 Optional Accessories

Flush Mount Installation Kit
Reverse Panel Gasket

Be sure to consult your marine electronics dealer for the Shakespeare antenna that best suits your particular installation. Shakespeare has been building a reputation for uncompromising quality in marine communications for more than 35 years. A reputation that our US Navy and Coast Guard have come to count on. So whether you selected your Shakespeare radio for peace of mind or for fun, we recommend you consult your Shakespeare marine electronics dealer for the wide variety of marine antennas and accessories available. He can help you select the system combination that best fits your boat and needs.

1.5 License Requirements

Pleasure boats (U.S. vessels), equipped with a marine radio, must have a Ship Station License. Other vessels (including compulsory equipped vessels) may require a Ship Radio Station License and a Commercial Radio Operator's License to operate the radio station. If the ship is not a U.S. vessel, contact the local authorities to determine licensing requirements.

When purchasing a new boat, a new station license must be applied for as the "Ship Station License" is not transferable. Therefore, upon the sale of your boat, the FCC requires that you submit your old license for cancellation. A change in mailing address requires notification to be filed with the FCC. This notification is mailed to:

Federal Communications Commission
P. O. Box 1040
Gettysburg, PA 17326

1.5.1 License Application

The Ship Radio Station License is obtained by filling out and submitting Form 506 with \$35 to the FCC. **DO NOT SEND CASH.** To operate the radio while waiting for the license to be returned from the FCC, fill out and keep the bottom part of Form 506. This "Temporary Permit" is good for 90 days from the date Form 506 is mailed to the FCC. Your Ship Station License is valid for a period of 5 years. The Call Sign for your station will be issued on the license and the temporary permit has instructions for assigning the vessel's temporary call sign. If the ship's radio station is to be operated in other countries, contact the local authorities for their licensing requirements. Mail form to:

Federal Communications Commission
Marine Ship Service
P. O. Box 358275
Pittsburgh, PA 15251-5275

1.5.2 Operator's License

A Restricted Radiotelephone Operator Permit is not required for domestic operation of a marine VHF radio for U.S. pleasure boats as long as you do not dock in any foreign ports. If you are going to dock in a foreign port or plan to leave a foreign port to dock in U.S. ports, it will be necessary to obtain the Restricted Permit. To do this, acquire, fill out and mail to the FCC a Form 753 along with a \$35 fee in the form of a single check or money order payable to the FCC. **DO NOT SEND CASH.** For further license information call the FCC at 717-337-1212.

1.6 Brief Operating Instructions

Please use the following brief operation instructions when first using the Shakespeare SE 2550 Marine VHF radio. Please remember that this section is not designed to replace a thorough study of the Owner's Manual. In addition, a waterproof quick card is provided for reference.

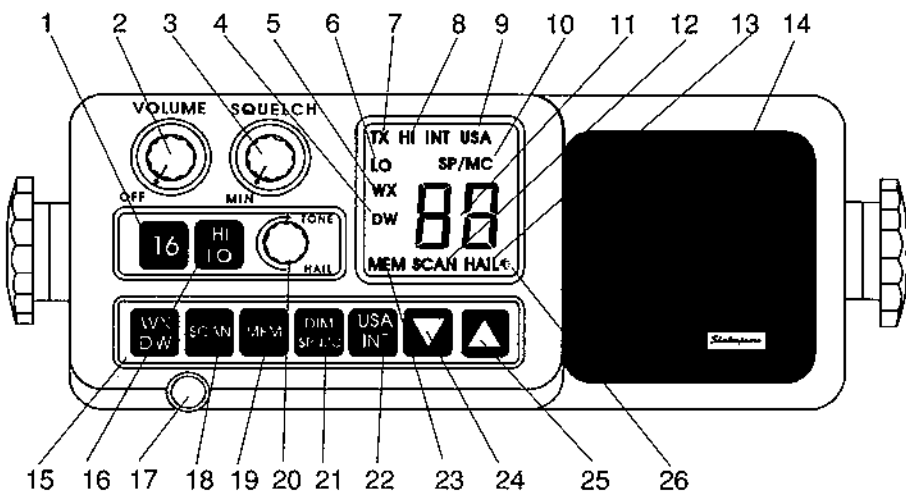

1-Channel 16 Priority select key

2-Power and Volume control

3-Squelch Control

4-Dual Watch active indicator

5-Weather Channel indicator

6-Lo Power Output indicator

7-Transmit active indicator

8-Hi Output power indicator

9-USA channels indicator

10-Speaker/Microphone indicator

11-Active channel indicator

12-Scan active indicator

13-Hailer active indicator

14-Speaker

15-Weather and Dual Watch select

16-HI/LO transmit power key

17-Microphone cable

18-Scan select key

19-Memory Key

20-Tone and Hailer control

21-Backlight DIM/Speaker Mic key

22-USA/International channel key

23-Memory indicator

24-Down channel select key

25-Up channel select key

26-Hail activation indicator

Brief Operations Table

POWER ON AND VOLUME

Turn the Volume control CLOCKWISE.

SQUELCH

Turn the Squelch Control knob counterclockwise until static is heard. Turn Squelch Control knob clockwise slowly, just until noise is no longer heard.

- BACKLIGHTING** Touch and release the **DIM** key to adjust backlighting to the desired brightness.
- USA/INT** This key changes the available channels to USA or International allocations. See Appendix A through D for complete channel listing and channel usage.
- SELECTING CHANNELS** Pressing the **UP/DOWN** arrow keys on the front panel, or the front of the microphone, scrolls through the available channels. The displayed channel is the active channel.
- EMERGENCY CALLING** Press **16** key for Channel 16. This channel is used to call the Coast Guard and general vessel calling. Always switch to another channel to chat.
- To leave Emergency-Calling Channel 16, press **WX/DW** or the Channel Select **UP/DOWN** arrow keys.
- TRANSMIT POWER** Press **HI/LO** to toggle between 1 Watt and 25 Watts transmit power.
- TRANSMIT** Press and hold the **Push-To-Talk** key on the top of the microphone to transmit.
- WEATHER CHANNELS** Touch and release **WX/DW** to access the last selected weather channel. To change Weather Channels, use the **UP/DOWN** arrow keys. To exit the Weather Mode press **16** or **WX/DW**.
- DUAL WATCH** Set Squelch, then select a channel other than Channel 16. Press and hold the **WX/DW** key until the radio beeps. DW is shown in the display. The radio scans both 16 and your selected channel to stop, press **16** or **WX/DW**.
- ALL SCAN** Set Squelch as mentioned and press **SCAN** key. To stop, press the **16** or **WX/DW** key. Memory Scan is an advanced feature. Refer to Section 3.2.13.
- SPEAKER MIKE** Press and hold the **DIM** key until speaker mike is activated, "SP/MC" is shown in the display.

NOTE

- 1 beep confirms a valid entry or selection.
- 3 beeps mean an invalid entry-PLEASE TRY AGAIN.

1.7 Technical Specifications

General

| | |
|---------------------------|--|
| Physical Characteristics: | Height: 2.5" Width: 6.0" Length: 8.0" including heatsink Weight: 2.0 lbs. |
| Temperature Range | -20 Deg C to +50 Deg C |
| Power Requirements | 13.8 VDC nominal, 5.5 A transmit, .2 A receive |
| Channels | 124 total, 57 USA, 57 International and 10 weather |

Transmitter

| | |
|---------------------|--|
| Output Power | 25 Watt/1 Watt |
| Output Impedance | 50 Ohms |
| Modulation | FM, 5 KHz max deviation |
| Frequency Stability | +/- .0005%(5ppm) |
| Spurious Emissions | 2.5 uW (-56 db) @ 1 Watt Tx 25 uW (-70 db) @ 25 Watt Tx |
| Hum and Noise | -40 db |
| Audio response | Less than 10% distortion at 3khz deviation. 6db/octave pre-emphasis Audio low pass filter included. |

Receiver

| | |
|---|--|
| Sensitivity | .25uV or less for 12db SINAD .50uV or less for 20db SINAD |
| Selectivity | -6db at 7.5 KHz -65db at 25 KHz |
| Spurious Response Attenuation | 70db min. |
| Intermodulation Spurious Response Attenuation | 70db min. |
| Audio Output Power | 3 Watts @ 8 Ohms 6 Watts @ 4 Ohms External/Hailer |
| Audio Distortion | 10% @ 3 Watts into 8 Ohms |
| Audio Response | +1/-3 db matching a 6db/octave de-emphasis from 300-3000Hz |
| Squelch Sensitivity | Threshold: .30 uV Max Full Squelch: .80 uV |

Specifications are subject to change without notice and are nominal unless otherwise indicated.

2.0 INSTALLATION

Before using the Shakespeare SE 2550 Marine VHF radio, please study the following section. Failure to adhere to these installation and operating considerations can damage or significantly degrade the performance of your VHF radio.

2.1 Unpacking And Inspection

The Shakespeare SE 2550 Marine VHF radio comes to you 100% inspected. When unpacking, check the parts shipped with the unit against the supplied parts list. If there is a discrepancy, notify your selling agent or Shakespeare Customer Service (1-803-276-5504).

If the radio was damaged during shipment, save ALL packing material to make it easier to file a claim with the carrier. All damage claims from shipment must be filed with the freight carrier used to ship the radio to you.

2.2 Mounting Preparation

Before actually mounting your new SE 2550 Marine VHF radio, take a little time to read over the installation instructions. You will find there are many things to take into consideration before drilling that first hole. Planning every aspect of the installation first, will save time and aggravation. It will also save money by cutting down potential errors that require repair to correct.

Before mounting begins you will need to purchase a marine VHF radio antenna. Shakespeare markets a full line of high quality marine VHF radio antennas to fit every installation. The dealer you purchased this radio from will be able to help you choose the antenna style best suited to your type of boating.

2.3 Mounting Location Selection

The following is a list of items that need advanced planning before selection of the mounting location. Be sure you can answer these questions fully.

1. Find where the vessel's +12 volt supply and ground are located and what it will take to get the radio power cable assembly to it.
2. Where can the antenna be mounted and what must be done to route the antenna cable to the radio?

NOTE

Keep the antenna at least 3 feet away from the radio and as high as possible for best performance.

3. Where is the best place to mount the radio itself? Keep in mind that the radio may be table top mounted, hang mounted overhead, bulkhead mounted vertically, under counter mounted and flush mounted using the optional Flush Mount Kit.
4. When deciding on a mounting location, visibility of the front panel, access to the front panel controls, access to the mounting knobs, room for rear cable connections and access to rear cable connections must be addressed and planned.

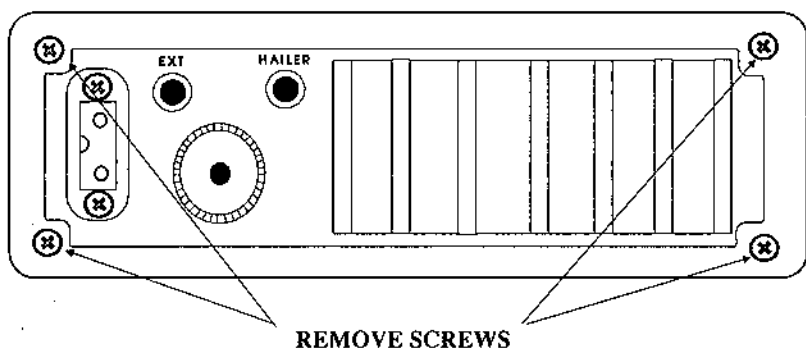

Figure 2-1 Screws to remove for front panel reversal.

2.4 Front Panel Reversal

For overhead and bulkhead installations follow these instructions to reverse the front panel. Do this before mounting the radio.

1. Disconnect all connections from the back of the radio. Then remove the four screws on the back of the unit securing the case to the chassis.
2. Slide the case off of the radio and replace the original front panel gasket with the reverse front panel gasket included with your radio packaging.
3. Rotate the case 180 degrees.
4. Tilt the display forward 40 degrees.
5. Slide the case back on the chassis. Do not pinch any wiring or cabling.
6. Seat the case on the front panel and re-install the screws on the back of the radio.
7. Mount the trunnion bracket on the top of the radio. Figure 2-2 shows the "before" and "after" results.

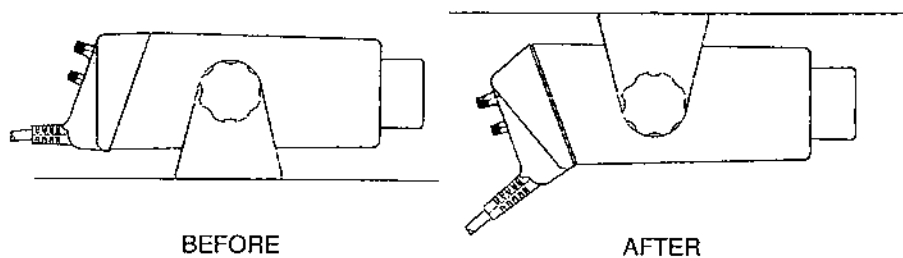

Figure 2-2 Front Panel Reversal Procedure.

2.5 Unit Mechanical Installation

Once a mounting location has been chosen, hold the mounting bracket at the place the unit is to be mounted. Use the mounting bracket as a template to mark the places to drill holes for the mounting screws. To mount the bracket into wood use stainless steel wood screws. If the unit is to be mounted into fiberglass, use stainless steel nuts and through bolts as the vibrations found on most pleasure boats will loosen self tapping screws mounted directly into fiberglass. When the mounting bracket is secured, attach the SE 2550 to the bracket using the mounting knobs supplied with the unit. For overhead and bulkhead installation reverse the front panel.

2.6 Electrical Connections

The back panel of the SE 2550 comes with the following standard connections.

1. Electrical Power (+12 volts and ground)
2. Antenna Connector (for PL-259 type connections)
3. External speaker (1/8 " phono plug receptacle)
4. Hailer speaker (1/8" phono plug receptacle)

2.6.1 Power Hookup

The SE 2550 is supplied with a power cable assembly. The free end of the cable is connected to the battery side of the vessel's +12 volt power buss. The cable is equipped with a 7 Amp in-line fuse holder for over-current protection. The **Red (+)** side of the cable is connected to +12 volt buss. The **Black (-)** side of the cable is connected to the Negative or Ground side of ship's power. After the power cable is connected to ship's power, plug the connector end into the back of the radio.

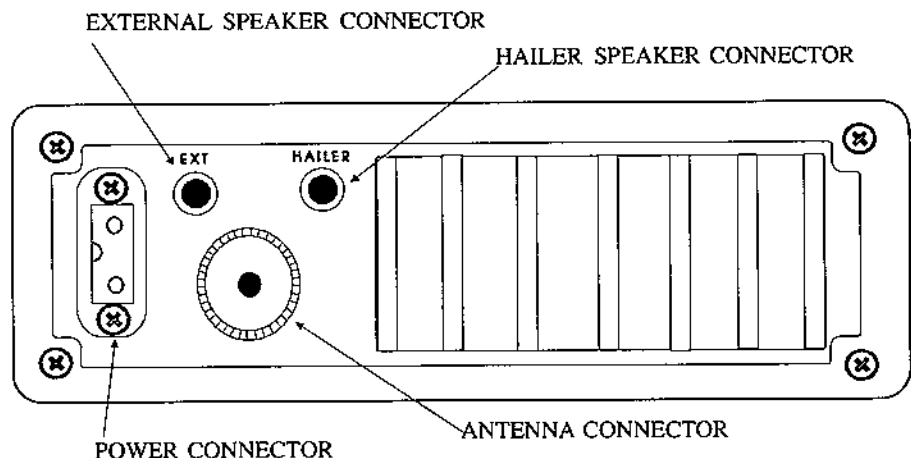

Figure 2-3 Rear panel electrical connections.

NOTE

Use at least 12 gauge wire to carry the transmit 5.5 Amp current. This wire size is appropriate for up to 20 feet of cable length.

When powering up the SE 2550, if no display appears once the power is turned on, check the power cable hookup polarity if the in-line fuse is blown. Remember to replace the fuse with one of the same 7 Amp rating. Using a fuse with a higher rating can result in permanent damage to the radio.

2.6.2 Antenna Connection

DO NOT attempt to operate the SE 2550 without the antenna connected, to do so can result in severe damage to the transmitter portion of the radio and void the warranty.

Plug the antenna cable PL-259 connector into the antenna connector on the rear panel of the SE 2550 Marine VHF radio. **ALWAYS** screw down the outer coupling ring of the connector tightly to ensure a solid connection.

2.6.3 Coax Connector Assembly

1. Trim back outer jacket of antenna coax back 1-1/8".
2. Trim back the braided shield to 13/16"
3. Trim back center insulation 3/4"
4. Slip the coupling ring over cable.

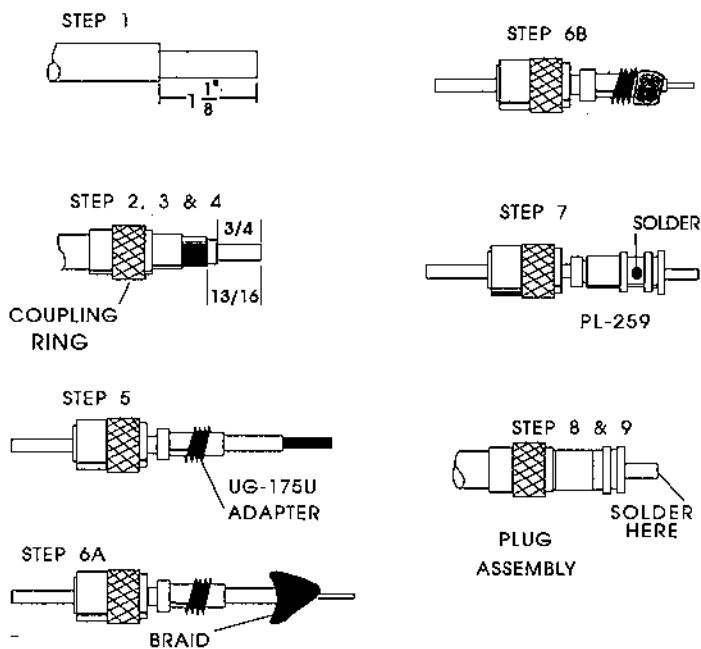

Figure 2-4 Coax Connector Assembly.

5. Insert cable through the middle of the UG-175U adapter.
6. Fold the braided shield back over the end of the UG-175U adapter. Be sure there is no shield wires touching the center conductor.
7. Screw the UG-175U adapter into the PL-259 connector while feeding the end of the center conductor of the cable through the hole at the end of the plug.
8. Solder the center conductor of the coax to the center of the PL-259 connector. Trim center conductor. Solder braided shield to the PL-259 connector via the small holes
9. Screw coupling ring onto the PL-259 connector.

NOTE

If you are not sure about this procedure, have a qualified marine radio service technician assist you.

2.6.4 External Speaker Connection

Under high noise conditions, it is often desirable to install a more powerful external speaker or use your speaker mike. Purchasing and mounting of the external speaker is left to the discretion of the owner as there is a great variety of external speakers available, but be sure a 4 ohm model capable of 8 watts is purchased. We recommend a watertight model for long service.

Obtain a 1/8" phono plug from your local electronics supply house. To connect your external speaker, solder the two leads from the speaker to the connections on a 1/8" phono plug. Next, plug the phono plug into the "EXT" external speaker connector on the back of the radio.

After installation is complete, the external speaker replaces the radio's internal speaker.

2.6.5 Hailer Connection

Generally, the hailer loud speaker is mounted high and facing the bow of the boat. Be sure a 4 ohm model capable of 8 watts is purchased. Obtain a 1/8" phono plug from your local electronics supply house. To connect the hailer, solder the two leads from the speaker to the connections on the 1/8" phono plug. Next, plug the phono plug into the "HAILER" loud speaker connector on the back of the radio. After installation is complete, turn the radio to the "HAIL" position, push **PTT** and speak into the microphone. Use the Volume Control to adjust to the desired audio power level.

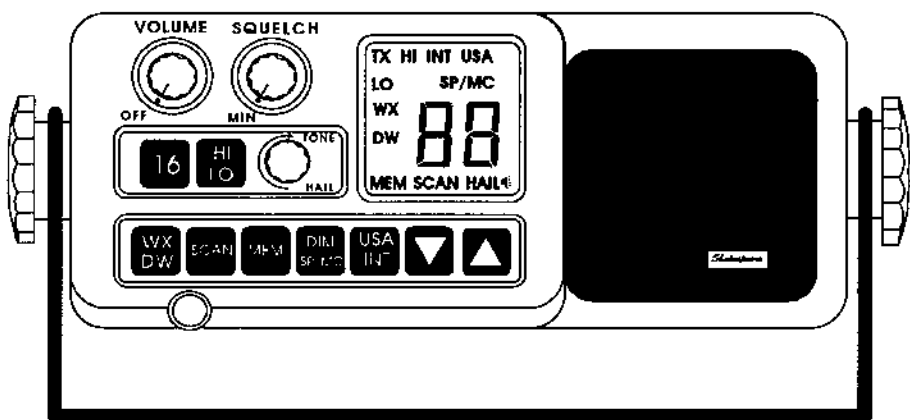

Figure 3-1. SE 2550 Front Control Panel.

3.0 OPERATION

Your Shakespeare 2550 Marine VHF radio is designed for the tough marine environment, with special attention paid to ease of operation. The following section helps you realize the maximum benefit of your purchase. The SE 2550 marine VHF radio is not only a communications convenience but a valuable tool in life threatening situations. This life saving potential makes thorough study of this Owner's manual extremely important.

3.1 Controls And Display

All controls and displayed information are on the front panel of the SE 2550. The upper left knob on the front panel controls Power ON and speaker volume. The upper right knob controls the squelch adjustment. The red backlit LCD display shows selected channel, transmit power setting, scan mode, hail mode, speaker mike mode and transmit mode. The tactile keypad, with individual switches behind the overlay, controls selection of receive and transmit channels, transmit power level, backlight brightness, speaker mike ON/OFF, dual channel watch, all channel scan, memory scan, weather channel access, USA or International channels and instant channel 16 priority select. A single beep of the radio indicates a valid keyboard entry. Three beeps means an invalid entry- PLEASE TRY AGAIN.

3.2 Operating Procedures

3.2.1 Power and Volume Control

To apply power to the SE 2550 VHF radio, turn the Volume Control knob (upper left control knob), clockwise. A “click” is heard and felt. At this point the display shows numbers and annunciators. The SE 2550 remembers the last channel and mode you were using before “TURN OFF” and goes to this same configuration at “TURN ON”.

VOLUME



OFF

The next thing to do is adjust the Squelch (see below). To do this, turn the Squelch Control knob counterclockwise until background noise is heard in the speaker. Now, the volume of the speaker can be adjusted to your desired level by the Volume Control.

Make this adjustment by turning the Volume Control back and forth until you are comfortable with the background noise level.

3.2.2 Display Backlighting

At power ON the display backlighting comes on at full intensity.

Press and release the **DIM** key to adjust the brightness level

down one step. Each press and release of the **DIM** key sets the brightness of the backlighting one step lower until the backlight is turned off.

DIM SELECT KEY

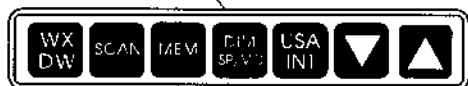

The brightness levels are full, medium, low and OFF. When the backlight is OFF, pressing the **DIM** key one time turns the backlighting on to full brightness.

3.2.3 Setting Squelch

To adjust the squelch setting, start by turning the Squelch control knob (front right control knob), all the way counterclockwise. Rotate the volume control knob counterclockwise until the background noise heard in the radio speaker is at a comfortable level. Next, when no radio transmissions are being heard, turn the Squelch control knob clockwise just to the point that the background noise is no longer heard.

SQUELCH This quiets the receiver between radio transmissions and still allows the incoming messages to be heard.



MIN

The level of squelch adjustment needed to quiet the radio static noise is dependent on the background noise intensity. Keep in mind that the squelch may need to be adjusted when listening to a different channel.

3.2.4 Channel Selection

Channel selection for the normal transmit/receive channels is handled by two separate sets of controls. One set of channel selection arrow keys is found on the front panel directly below the LCD readout. The other set is found on the front of the speaker microphone. The current active channel selection is viewed in the LCD display.

CHANNEL SELECT KEYS

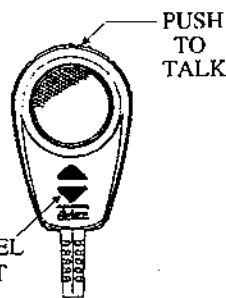

To change channels using either set of arrows, simply press the **UP/DOWN** arrow keys. Observe the changing channels in the LCD display. From your present channel, pressing the **UP** arrow key will increase the channel numbers. In the same respect, from your present channel, pressing the **DOWN** arrow key decreases the channel numbers. If the highest or lowest channel available is reached and the pressing of the arrow key is continued, the channel numbers will cycle around to the top or bottom of the list and continue changing. Holding the **UP** or **DOWN** changes the channel at a rapid rate. Practice several times to become accustomed to this. Some channels have no Tx function (ie. 15, 75, 76 guard channels). Please study the channel allocation list in the Appendix to become familiar with the proper and customary usage.

3.2.5 U.S.A/International Channel Select

The SE 2550 is programmed to access both United States and International channels. Which set of channels you use is determined by the area of operation. Normally in U.S. coastal areas and ports, the USA channels are selected.

To toggle between USA and International channels, press the **USA/INT** key. The channel type selected is indicated in the display.

CHANNEL TYPE INDICATOR

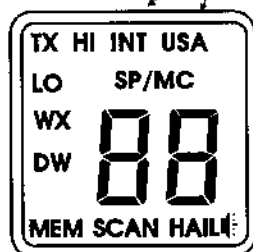

3.2.6 Voice Transmitting

Until you memorized the proper usage of each channel, refer to the channel Assignment Appendices before attempting to make a Voice Transmission. There you will find a listing of the channels and their usage.

Once the proper channel has been selected, locate the **Push-To-Talk** key on the top of the microphone. The **Push-To-Talk** key will be referred to as the **PTT** key. To transmit, press and hold **PTT** for the entire transmission. While **PTT** is held in, speak into the microphone slowly and clearly. While the **PTT** key is being held, "TX" appears in the LCD display. When the transmission is complete, release the **PTT** key.

3.2.7 High/Low Transmit Power

The SE 2550 has two transmit power output levels, 1 Watt and 25 Watts. The low power level (1 Watt) is provided for situations where the two parties involved are close to each other. This reduces the congestion on the same channel in areas far away, allowing more individuals to use a channel at one given time.

To toggle the power output selection between "LO" and "HI" press the **HI/LO** key. The transmit power output level is displayed in the LCD display window.

3.2.8 Transmitter 5 Minute Time Out

In the event that the **PTT** key is held in for too long, the transmitter timer will disengage the transmit function after 5 minutes. The **PTT** must be lifted and pressed again to continue transmission. This is designed to prevent a channel from accidentally being tied up by a malfunctioning microphone or transmitter.

3.2.9 Weather Channels Access

Your SE 2550 has the ability to monitor NOAA and International Weather Service broadcast. This safety feature allows you to listen to weather reports at any time

so changes can be made in your boating plans. This allows you to alter your planned course and to make shipboard preparations.

To change from standard marine VHF channels to the weather channel broadcast, touch and release the **WX/DW** key. "WX" appears in the LCD display indicating that weather channel reception is now active. The initial weather channel displayed, is the last one used. Use the channel change arrow keys on the microphone or the front panel to select another weather channel.

To cancel weather channel access, press the **WX/DW** or the **16** key. Pressing of other keys (except for the backlighting **DIM** key), while in the weather channel mode, will cause a 3 beep tone to be heard indicating an invalid key press.

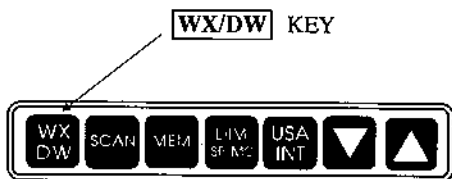

3.2.10 Channel 16 Priority

RED CH **16** KEY

As a convenience and safety feature, the SE 2550 marine VHF radio has a channel **16** priority key. Pressing this key from any mode or channel immediately changes the selected channel to channel 16 with the power output changed to "HI".



3.2.11 Channel 13/67 High Power Override

Due to the special usage FCC assigned channels 13 and 67, are restricted to 1 Watt under normal conditions. In some situations it is acceptable to override this output level and transmit on channels 13 and 67 at 25 Watts. To do this, press and hold the **HI/LO** key on the front panel of the radio, for the duration of the transmission. The LCD display shows "HI" in the display window while the **HI/LO** key is held in. Upon releasing the **HI/LO** key, transmit output power is dropped back to 1 Watt. When another appropriate marine VHF channel is selected, the **HI/LO** key toggles the transmit power setting between 1 and 25 watts, and does not have to be held in for "HI" power.

3.2.12 All Channel Scan

The SE 2550 has the ability to scan through all available channels. To do this, proper squelch adjustment is most important.

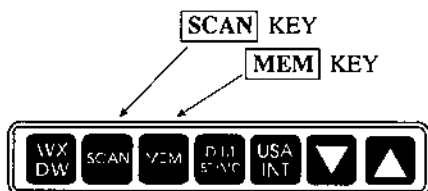

Press the **SCAN** key. The channel indications displayed in the LCD display on the front panel will begin to cycle through all available channels. If a Squelch Break occurs on any of the channels while being scanned, the scanning stops on that channel.

The SE 2550 resumes scanning 4 seconds after the end of the squelch break unless the **PTT** key on the Mike is pressed. If you key the mike, a beep is heard, the scan operation is canceled and your SE 2550 remains on the selected channel.

The All Channel Scan is canceled at any time by pressing the **16**, **WX/DW**, **SCAN** or **MEM** keys.

3.2.13 Memory Scan

The Memory Scan feature of the SE 2550 allows programming the scan function to 10 selected channels of your choice. Proper adjustment of the Squelch Control is necessary for this function to correctly operate.

STORING: To store a channel in the memory bank, use the arrow key on the front panel or on the front of the microphone to select the desired channel. Press and hold

the **MEM** key until second beep is heard (about 1 second). The channel showing in the display is placed into the memory bank. If the channel is already in memory, NO beep is heard.

If you wish to enter more channels into memory, wait until the "MEM" annunciator is out and repeat the above step for up to nine more channels to make a total of ten. If an attempt is made to store a channel in memory when it is full, a 3 beep tone is heard and "FL" appears in the LCD display for 1 second.

SCAN LIST REVIEW: To review the channels stored, briefly touch and release the **MEM** key. "MEM" and the stored channel appears in the LCD display. Each quick touch of the **MEM** key sequentially shows the channels you have stored in the memory bank.

SCANNING THE MEMORY BANK: Press the **MEM** key. "MEM" annunciator appears. Then press the **SCAN** key. "SCAN" also appears in the display and the channel display begins to cycle through the channels stored in the memory bank. When a squelch break occurs, the display stops and remains on that channel for 4 seconds after the squelch break ends. The scan process then continues.

If the **PTT** key on the microphone is pressed, a beep tone is heard and the memory scan mode is turned off. Communication on the displayed channel continues. Pressing the **16** key, **WX**, **DW** or the **SCAN** keys will cancel the memory scan operation.

CLEARING A CHANNEL: To clear a channel stored in scan memory, press and hold the **MEM** key about 3.5 seconds until "CL" appears in the LCD Display and a beep is heard. ALWAYS MAKE SURE THE "MEM" ANNUNCIATOR IS OUT BEFORE ATTEMPTING TO CLEAR A CHANNEL FROM MEMORY. The SE 2550 remembers your stored channels even if the radio is OFF. To completely erase the memory bank, either repeat the process until all channels are clear or HOLD DOWN the **MEM** key while turning ON the SE 2550 until "CL" appears in the LCD and a beep sounds.

3.2.12 Dual Watch

The Dual Watch feature allows you to monitor channel 16 and ONE other channel. To make use of this feature the squelch must be properly set. Once the squelch is set, select the "other" channel using the channel select arrow keys on the front panel or front of the microphone. Next, press and hold **WX/DW** key until "DW" appears in the LCD display. The channel display then changes between Channel 16 and the "other" channel until a squelch break occurs. The channel displayed at this time is held in the display for 4 seconds after the Squelch Break ends.



Pushing the **PTT** key disables the Dual Watch mode at any time. Also, pressing the channel arrow keys, **16**, or the **WX/DW** key turns the Dual Watch mode OFF. Any other key press produces 3 quick beeps and results in no change in current configuration.

3.2.15 Hailer Operation

The hailer function is activated by turning the TONE control knob counterclockwise until a click is heard and/or felt. "HAIL" is annunciated in the LCD with no channel digits shown. Next, turn the volume control down and press the **[PTT]** key. The horn symbol appears. Speak into the Mike to test the hailer output level. Adjust the volume control until the hailer loud speaker output level is satisfactory. To leave Hailer Mode, turn the TONE control knob clockwise until a "click" is heard and/or felt. Your last active channel is displayed.

3.2.16 External Speaker Operation

When the optional external speaker is connected to the SE 2550 the speaker on the front panel is disabled automatically. The volume is adjusted in the same way as it is for the front panel speaker using the volume control knob.

3.2.17 Tone Control

The tonal quality of the received signals can be adjusted by turning the "TONE" control knob to a position that produces the most pleasing sounds.

3.2.18 Speaker Mike

The SE 2550 has a speaker microphone as a standard feature. Placing this Speaker Mike near your ear provides more convenient listening in high noise situation.

To activate the Speaker Mike function, press and hold the **[DIM/SP/MC]** key on the front of the SE 2550 until a beep tone is heard. This activates the speaker found in the microphone in addition to the radios internal speaker. "SP/MC" is shown in the display while the Speaker Mike is active.

3.3 Methods Of Operation

The marine VHF radio channels are becoming increasingly crowded. This makes it very important and every users responsibility to help relieve channel congestion through use of professional radio techniques. The following the suggested rules will help everyone using marine VHF.

1. Before transmitting, listen to the channel for traffic already in progress. This will stop you from interfering with others using the channel ahead of you. Keep your transmissions as brief as possible but still make your message understood.
2. Give distress calls PRIORITY, unless you are in a position to help. Do not transmit but continue to listen.
3. If there is no response to your call, wait 2 minutes before trying again.

4. Calls on channel 16 should be less than 30 seconds in length. Once contact is established, switch to another channel that is more appropriate for your type of communication. Refer to the Appendices on channel assignment for the correct channels to use. Use professional terminology by referring to the Glossary and the phonetic alphabet found in Appendix E.

4.0 APPENDIX

APPENDIX A - USA VHF MARINE CHANNEL ASSIGNMENTS

| CHANNEL | | TRANSMIT | MODE | RECEIVE |
|---------|-----------------------------|----------|------|---------|
| 01A | Port Operations | 156.050 | S | 156.050 |
| 02A | Port Operations | 156.100 | S | 156.100 |
| 03A | Port Operations | 156.150 | S | 156.150 |
| 04A | Port Operations | 156.200 | S | 156.200 |
| 05A | Port Operations | 156.250 | S | 156.250 |
| 06 | Intership Safety | 156.300 | S | 156.300 |
| 07A | Commercial, Intership | 156.350 | S | 156.350 |
| 08 | Commercial, Intership | 156.400 | S | 156.400 |
| 09 | Com'l/Non-Commercial | 156.450 | S | 156.450 |
| 10 | Commercial, Intership | 156.500 | S | 156.500 |
| 11 | Commercial, Intership | 156.550 | S | 156.550 |
| 12 | Port Operations | 156.600 | S | 156.600 |
| 13* | Bridge to Bridge, 1W | 156.650 | S | 156.650 |
| 14 | Port Operations | 156.700 | S | 156.700 |
| 15* | Environmental (Rec. only) | ----- | S | 156.750 |
| 16 | Distress, Safety & Calling | 156.800 | S | 156.800 |
| 17* | Maritime Control, 1 W | 156.850 | S | 156.850 |
| 18A | Commercial, Intership | 156.900 | S | 156.900 |
| 19A | Commercial, Intership | 156.950 | S | 156.950 |
| 20A | Port Operations | 157.000 | S | 157.000 |
| 21A | U.S. Government Only | 157.050 | S | 157.050 |
| 22A | Liaison USCG Only | 157.100 | S | 157.100 |
| 23A | Port Operations, Gov't only | 157.150 | S | 157.150 |
| 24 | Public Correspondence | 157.200 | D | 161.800 |
| 25 | Public Correspondence | 157.250 | D | 161.850 |
| 26 | Public Correspondence | 157.300 | D | 161.900 |
| 27 | Public Correspondence | 157.350 | D | 161.950 |
| 28 | Public Correspondence | 157.400 | D | 162.000 |
| 60 | Public Correspondence | 156.025 | S | 156.025 |
| 61A | Public Correspondence | 156.075 | S | 156.075 |
| 62A | Public Correspondence | 156.125 | S | 156.125 |
| 63A | Com'l, Port Operations | 156.175 | S | 156.175 |
| 64A | Public Correspondence | 156.225 | S | 156.225 |
| 65A | Port Operations | 156.275 | S | 156.275 |
| 66A | Port Operations | 156.325 | S | 156.325 |
| 67* | Bridge-to-Bridge, 1W | 156.375 | S | 156.375 |
| 68 | Non-Commercial | 156.425 | S | 156.425 |
| 69 | Non-Commercial | 156.475 | S | 156.475 |
| 70 | Digital Selective Calling | 156.525 | S | 156.525 |
| 71 | Non-Commercial | 156.575 | S | 156.575 |
| 72 | Non-Commercial | 156.625 | S | 156.625 |
| 73 | Port Operations | 156.675 | S | 156.675 |

| CHANNEL | | TRANSMIT | MODE | RECEIVE |
|---------|----------------------------|----------|------|---------|
| 74 | Port Operations | 156.725 | S | 156.725 |
| 75 | Guardband (Rec. only) | ----- | S | 156.775 |
| 76 | Guardband (Rec. only) | ----- | S | 156.825 |
| 77 | Intership, Port Operations | 156.875 | S | 156.875 |
| 78A | Non-Commercial | 156.925 | S | 156.925 |
| 79A | Commercial, Intership | 156.975 | S | 156.975 |
| 80A | Commercial, Intership | 157.025 | S | 157.025 |
| 81A | U.S. Government Only | 157.075 | S | 157.075 |
| 82A | U.S. Government Only | 157.125 | S | 157.125 |
| 83A | U.S. Government Only | 157.175 | S | 157.175 |
| 84 | Public Correspondence | 157.225 | D | 161.825 |
| 85 | Public Correspondence | 157.275 | D | 161.875 |
| 86 | Public Correspondence | 157.325 | D | 161.925 |
| 87 | Public Correspondence | 157.375 | D | 161.975 |
| 88A | Commercial, Intership | 157.425 | S | 157.425 |

* = 1 Watt

** = 1 Watt initially, HI/LO must be held for 25 Watt.

APPENDIX B - VHF MARINE WEATHER CHANNEL ASSIGNMENTS

| CHANNEL | | RECEIVE |
|---------|--|---------|
| WX1 | Weather (Receive only) - NOAA | 162.550 |
| WX2 | Weather (Receive only) - NOAA | 162.400 |
| WX3 | Weather (Receive only) - NOAA | 162.475 |
| WX4 | Weather (Receive only) - CANADA | 162.425 |
| WX5 | Weather (Receive only) | 162.450 |
| WX6 | Weather (Receive only) | 162.500 |
| WX7 | Weather (Receive only) - CANADA | 162.525 |
| WX8 | Weather (Receive only) - ENVIRONMENTAL | 161.650 |
| WX9 | Weather (Receive only) | 161.775 |
| WX10 | Weather (Receive only) | 163.275 |

APPENDIX C - INTERNATIONAL VHF MARINE CHANNEL

| CHANNEL | | TRANSMIT | MODE | RECEIVE |
|---------|-------------------------------------|----------|------|---------|
| 01 | Public Corresp., Port Ops | 156.050 | D | 160.650 |
| 02 | Public Corresp., Port Ops | 156.100 | D | 160.700 |
| 03 | Public Corresp., Port Ops | 156.150 | D | 160.750 |
| 04 | Public Corresp., Port Ops | 156.200 | D | 160.800 |
| 05 | Public Corresp., Port Ops | 156.250 | D | 160.850 |
| 06 | Intership Safety | 156.300 | S | 156.300 |
| 07 | Public Corresp., Port Ops | 156.350 | D | 160.950 |
| 08 | Commercial, Intership | 156.400 | S | 156.400 |
| 09 | Com'l/Non-Com'l | 156.450 | S | 156.450 |
| 10 | Commercial, Intership | 156.500 | S | 156.500 |
| 11 | Commercial, Intership | 156.550 | S | 156.550 |
| 12 | Port Operations | 156.600 | S | 156.600 |
| 13** | Bridge-to-Bridge, 1 W | 156.650 | S | 156.650 |
| 14 | Port Operations | 156.700 | S | 156.700 |
| 15 | Onboard Communications, (Rec. only) | ----- | S | 156.750 |
| 16 | Distress, Safety and Calling | 156.800 | S | 156.800 |
| 17* | Maritime Control, 1 W | 156.850 | S | 156.850 |
| 18 | Port Operations | 156.900 | D | 161.500 |
| 19 | Commercial, Intership | 156.950 | D | 161.550 |
| 20 | Public Correspondence | 157.000 | D | 161.600 |
| 21 | Public Correspondence | 157.050 | D | 161.650 |

| CHANNEL | | TRANSMIT | MODE | RECEIVE |
|---------|----------------------------|----------|------|---------|
| 22 | Public Correspondence | 157.100 | D | 161.700 |
| 23 | Public Correspondence | 157.150 | D | 161.750 |
| 24 | Public Correspondence | 157.200 | D | 161.800 |
| 25 | Public Correspondence | 157.250 | D | 161.850 |
| 26 | Public Correspondence | 157.300 | D | 161.900 |
| 27 | Public Correspondence | 157.350 | D | 161.950 |
| 28 | Public Correspondence | 157.400 | D | 162.000 |
| 60 | Public Corresp., Port Ops | 156.025 | D | 160.625 |
| 61 | Public Corresp., Port Ops | 156.075 | D | 160.675 |
| 62 | Public Corresp., Port Ops | 156.125 | D | 160.725 |
| 63 | Public Corresp., Port Ops | 156.175 | D | 160.775 |
| 64 | Public Corresp., Port Ops | 156.225 | D | 160.825 |
| 65 | Public Corresp., Port Ops | 156.275 | D | 160.875 |
| 66 | Public Corresp., Port Ops | 156.325 | D | 160.925 |
| 67** | Bridge-To-Bridge, 1 W | 156.375 | S | 156.375 |
| 68 | Non-Commercial | 156.425 | S | 156.425 |
| 69 | Non-Commercial | 156.475 | S | 156.475 |
| 70 | Digital Selective Calling | 156.525 | S | 156.525 |
| 71 | Port Operations | 156.575 | S | 156.575 |
| 72 | Non-Commercial | 156.625 | S | 156.625 |
| 73 | Port Operations | 156.675 | S | 156.675 |
| 74 | Port Operations | 156.725 | S | 156.725 |
| 75 | Guardband (Rec. only) | ----- | S | 156.775 |
| 76 | Guardband (Rec. only) | ----- | S | 156.825 |
| 77 | Intership, Port Operations | 156.875 | S | 156.875 |
| 78 | Public Corresp., Port Ops, | 156.925 | D | 161.525 |
| 79 | Public Corresp., Port Ops, | 156.975 | D | 161.575 |
| 80 | Public Corresp., Port Ops, | 157.025 | D | 161.625 |
| 81 | Public Corresp., Port Ops, | 157.075 | D | 161.675 |
| 82 | Public Corresp., Port Ops, | 157.125 | D | 161.725 |
| 83 | Public Corresp., Port Ops, | 157.175 | S | 161.775 |
| 84 | Public Correspondence | 157.225 | D | 161.825 |
| 85 | Public Correspondence | 157.275 | D | 161.875 |
| 86 | Public Correspondence | 157.325 | D | 161.925 |
| 87 | Public Correspondence | 157.375 | D | 161.975 |
| 88 | Public Corresp., Port Ops, | 157.425 | D | 162.025 |

* = 1 Watt

** = 1 Watt initially, HI/LO must be held for 25 Watts

APPENDIX D - CANADIAN VHF MARINE CHANNEL ASSIGNMENTS (INFOMATION ONLY)

| CHANNEL | | TRANSMIT | MODE | RECEIVE |
|---------|-----------------------|----------|------|---------|
| 01+ | Public Correspondence | 156.050 | D | 160.650 |
| 02+ | Public Correspondence | 156.100 | D | 160.700 |
| 03+ | Public Correspondence | 156.150 | D | 160.750 |
| 04 | Intership | 156.200 | S | 156.200 |
| 05 | Public Correspondence | 156.250 | S | 156.250 |
| 06 | Intership, Safety | 156.300 | S | 156.300 |
| 07+* | Commercial, Intership | 156.350 | S | 156.350 |
| 08+* | Commercial, Intership | 156.400 | S | 156.400 |
| 09* | Commercial, Intership | 156.450 | S | 156.450 |
| 10 | Commercial, Intership | 156.500 | S | 156.500 |
| 11+* | Commercial, Intership | 156.550 | S | 156.550 |
| 12+* | Port Operations | 156.600 | S | 156.600 |
| 13 | Bridge-To-Bridge, 1 W | 156.650 | S | 156.650 |

| CHANNEL | | TRANSMIT | MODE | RECEIVE |
|---------|-------------------------------------|----------|------|---------|
| 14+** | Port Operations | 156.700 | S | 156.700 |
| 15 | On Board Communications (Rec. only) | ----- | S | 156.750 |
| 16 | Distress, Safety & Calling | 156.800 | S | 156.800 |
| 17 | Maritime Control | 156.850 | S | 156.850 |
| 18+* | Commercial, Intership | 156.900 | S | 156.900 |
| 19 | Commercial, Intership | 156.950 | S | 156.950 |
| 20 | Port Operations | 157.000 | D | 161.600 |
| 21 | Coast Guard | 157.050 | S | 157.050 |
| 22+* | Coast Guard | 157.100 | S | 157.100 |
| 23+ | Public Correspondence | 157.150 | D | 161.750 |
| 24+* | Public Correspondence | 157.200 | D | 161.800 |
| 25+ | Public Correspondence | 157.250 | D | 161.850 |
| 26 | Public Correspondence | 157.300 | D | 161.900 |
| 27+* | Public Correspondence | 157.350 | D | 161.950 |
| 28+ | Public Correspondence | 157.400 | D | 162.000 |
| 60+ | Public Correspondence | 156.025 | D | 160.625 |
| 61^ | Coast Guard | 156.075 | S | 156.075 |
| 62^ | Coast Guard | 156.125 | S | 156.125 |
| 63 | Ship-to-Ship | 156.175 | S | 156.175 |
| 64^+ | Public Correspondence | 156.225 | S | 156.225 |
| 65** | Port Operations | 156.275 | S | 156.275 |
| 66** | Port Operations | 156.325 | S | 156.325 |
| 67+* | Commercial, Intership | 156.375 | S | 156.375 |
| 68+* | Non-Commercial | 156.425 | S | 156.425 |
| 69+* | Non-Commercial | 156.475 | S | 156.475 |
| 70+* | Non-Commercial | 156.525 | S | 156.525 |
| 71+* | Non-Commercial | 156.575 | S | 156.575 |
| 72+ | Non-Commercial | 156.625 | S | 156.625 |
| 73+* | Port Operations | 156.675 | S | 156.675 |
| 74+* | Port Operations | 156.725 | S | 156.725 |
| 77** | Commercial, Intership | 156.875 | S | 156.875 |
| 78 | Non-Commercial | 156.925 | S | 156.925 |
| 79+* | Commercial, Intership | 156.975 | S | 156.975 |
| 80+* | Commercial, Intership | 157.025 | S | 157.025 |
| 81* | Coast Guard | 157.075 | S | 157.075 |
| 82* | Coast Guard | 157.125 | S | 157.125 |
| 83+* | Coast Guard, Auxiliary | 157.175 | S | 157.175 |
| 84+ | Public Correspondence | 157.225 | D | 161.825 |
| 85+ | Public Correspondence | 157.275 | D | 161.875 |
| 86+ | Public Correspondence | 157.325 | D | 161.925 |
| 87+ | Public Correspondence | 157.375 | D | 161.975 |
| 88+* | Commercial, Intership | 157.425 | D | 162.025 |

^ = Atlantic Coast only

+ = Pacific Coast only

* = St. Lawrence River area only

** = St. Lawrence River area 1 WATT MAXIMUM

APPENDIX E - PHONETIC ALPHABET AND GLOSSARY

The following list consist of the standard phonetic alphabet, normally used to clarify the transmission of a series of letters.

| | | |
|-------------|--------------|-------------|
| A - Alpha | J - Juliette | S - Sierra |
| B - Bravo | K - Kilo | T - Tango |
| C - Charlie | L - Lima | U - Uniform |
| D - Delta | M - Mike | V - Victor |
| E - Echo | N - November | W - Whiskey |
| F - Foxtrot | O - Oscar | X - X Ray |
| G - Golf | P - Pappa | Y - Yankee |
| H - Hotel | Q - Quebec | Z - Zulu |
| I - India | R - Romeo | |

AFFIRMATIVE, used as an answer indicating "yes".

ANTENNA, any part of a radio transmitter that radiates radio energy.

BREAK, used to separate the text from other parts of a message or to separate one message from another.

CHANNEL, a particular frequency or pair of frequencies.

COAX, an electrical conductor used to carry radio energy from the transmitter to the antenna. Normally, the coax has an inner conductor insulated from the outer braided wire shield.

I SPELL, indicates the operator is going to spell the following word, usually using the phonetic alphabet.

MAYDAY, the English of the French M'aidez, "Help Me!"

NEGATIVE, used to indicate an answer of "no". Simply answering yes or no is easily misunderstood when a transmission is weak or noisy.

OUT, signals that the transmission has ended and no reply is expected.

OVER, ends a message and indicates a reply is expected.

ROGER, signals that the message was received satisfactorily.

STANDBY, simply means to wait.

WILCO, this message is a reply that indicates the previous message was received, understood and will be carried out.

SHAKESPEARE LIMITED WARRANTY

Shakespeare Company, Inc. (Shakespeare) warrants your VHF radiotelephone or related accessory for two years from date of original purchase against manufacturing defects in material and workmanship in accordance with the following terms and conditions. This warranty applies to the original purchaser only and is not transferable.

During the warranty period, Shakespeare will repair or replace without charge valid defects in material and workmanship. Warranty does not apply to products that have been damaged through accident, misuse, negligence, modification, alteration, abuse, or normal expected wear. Damage that is determined to be of this nature will be repaired at the consumer's expense.

Products which have had the serial number modified, defaced or removed will not be eligible for repair under this limited warranty.

Shakespeare will not be liable for damages consequential and otherwise arising from the use or inability to use this product. Shakespeare's liability is limited to the repair or replacement of the equipment during the warranty period.

Repairs or adjustments covered under this warranty are to be determined by Shakespeare.

We require proof of original purchase date for warranty determination. A copy of the sales invoice or canceled check is satisfactory evidence. This procedure insures that you receive full-term warranty from the date of original purchase so that the time the unit remains in dealer stock is not deducted.

After the first 30 days following the original date of purchase, all shipping charges to return units for repair are the responsibility of the customer. Please pack the unit carefully to eliminate shipping damage. It is wise to insure shipments against loss or damage. Return the unit to Shakespeare Company, Electronics and Fiberglass Division, RFD 3, P.O. Box 733, Newberry, SC 29108, Attention: Warranty Repair Department. Please include a detailed description of the problem you are experiencing along with proof of purchase. Shakespeare will return the repaired unit to you prepaid. Inquiries concerning the status of a warranty claim may be sent to the address above or expedited by telephoning (803) 276-5504 and asking for the Warranty Service Department.

This warranty gives you specific legal rights, and you may also have other rights which vary from state to state.

Prior to returning a unit, we encourage you to contact the Shakespeare Consumer Service Department by telephone or letter to discuss the nature of the problem. Many times a satisfactory solution can be reached without the need of returning the item.

The Consumer Service Department is also available for out of warranty service and to assist you with any questions or problems associated with the Shakespeare product you purchased.

WARRANTY AND POLICY ARE SUBJECT TO CHANGE WITHOUT PRIOR NOTICE

SHAKESPEARE COMPANY
Electronics and Fiberglass Division
RFD 3 P.O. Box 733
Newberry, SC 29108

Phone 803-276-5504 Fax 803-276-8940

Shakespeare[®]

 an Anatomy Industries company

MARINE VHF TRANSCEIVER EMERGENCY OPERATION PROCEDURE

1. Select Channel 16.
2. Press microphone button.
3. Say, "**MAYDAY-MAYDAY-MAYDAY. THIS IS (vessel name), (vessel name), (vessel name), (call letters), MAYDAY.**"
4. Tell where you are. (Be as precise as possible.)
5. State the nature of your distress.
6. Give number of adults and children on board and describe any injuries.
7. Estimate the seaworthiness of your vessel.
8. Briefly describe your vessel.
9. Say, "**I WILL BE LISTENING ON CHANNEL 16.**"
10. End with, "**THIS IS (VESSEL NAME & CALL SIGN), OVER.**"
11. Release the microphone button and listen for a reply. If no reply, repeat distress call. If there is still no answer, switch to another channel and repeat the distress call.

The logo for Shakespeare Company, featuring the word "Shakespeare" in a stylized, cursive script font. The logo is centered between two thick, solid black horizontal bars.

A *an Anthony Industries company*

SHAKESPEARE COMPANY
Electronics and Fiberglass Division
RFD 3 P.O. Box 733
Newberry, SC 29108
Phone 803-276-5504 Fax 803-276-8940

Copyright 1992 Shakespeare Company

REV 2

Shakespeare

SINCE 1897

ELECTRONICS & FIBERGLASS DIVISION

A an Anthony Industries company

SHAKESPEARE VHF MODEL SE 2550 OR SE 2500 REVERSE PANEL GASKET INSTALLATION PROCEDURE

To reverse the front panel of your Model SE 2550 or SE 2500 Marine VHF Radio for Overhead or Bulkhead mounting, a special Reverse Panel Gasket is provided to you from Shakespeare. Please call the toll free number below for the required gasket:

1-800-845-7750 (EXT 320)

When you have received this gasket, follow the instructions below and study the guidelines in your Owner's Manual in Section 2.4 page #8, for proper installation. It is important to assure you have a proper watertight fit.

1. Disconnect all connections from the back of the radio and remove the four screws on the back of the unit securing the plastic cover case to the metal chassis.

2. Slide the cover case off the radio and remove the existing front panel gasket. DO NOT turn or touch any of the radio internal component settings or adjustments. They are factory aligned.

3. Identify the White Dot on the Reverse Panel Gasket you have just received. This White Dot is on the TOP BACK SIDE of the gasket and will face the top rear of the radio when installed properly. The side of the gasket with the female slotted groove goes entirely around the plastic front display panel male lip. Slide the gasket over the chassis and place around the front display panel accordingly. Check again and be sure the White Dot is on the TOP of the radio nearest the Volume and Squelch Knobs and NOT on the bottom nearest the Keypad area.

4. Rotate the radio's cover case 180 degrees.

5. Tilt the front display panel assembly itself down about 40 degrees. The panel assembly easily rotates in the hinged slots located between the front display panel and the metal chassis of the radio. There is no need to loosen the 4 brass hinge screws.

6. Slide the radio's cover case back on the chassis. DO NOT pinch any radio wiring or cabling and check that the rear chassis sealing gasket remains properly in place.

7. Seat the cover case onto the Reverse Panel Gasket. Re-install the four cover case screws you removed in Step #1. Do not overtighten at this point. Gently lift the edge of the Reverse Panel Gasket all around the cover case with your fingernail to assure a positive fit and no gasket binding. Then, tighten the rear screws snugly. Double check for a smooth, proper fit of the Reverse Panel Gasket all around the radio's case. When properly installed, there should be no bulging or warping of the gasket.

8. Mount the trunion bracket on the top of the radio as shown in Figure 2.2 on page #9 of your Owner's Manual for your vessel's proper Overhead or Bulkhead installation.